

www.matasmakina.com



Çalı Sanayi Böl. Eflatun Cad. No: 14 Nilüfer | BURSA | TÜRKİYE
Mail: matas@matasmakina.com | export@matasmakina.com
Whatsapp No: +90 (533) 420 23 10
Tel | Ph: +90 (224) 482 42 44





EFE 01
SET ÜSTÜ MANUEL
TABLE TOP MANUAL

 KG 105 kg	 500
 a b h 670x760x800 (a) (b) (h)	 0,37 kw 220 V



EFE 02
SET ÜSTÜ OTO. KAPAKLI
TABLE TOP AUTO. BY COVER

 KG 108 kg	 250
 a b h 610x760x880 (a) (b) (h)	 0,37 kw 220 V



EFE 02-1
SET ÜSTÜ OTO. SENSÖRLÜ
TABLE TOP AUTO. BY SENSOR

 KG 105 kg	 350
 a b h 610x760x720 (a) (b) (h)	 0,37 kw 220 V



EFE 03
PRATİKO MANUEL
PRATICO MANUAL

 KG 164 kg	 500
 a b h 705x790x1310 (a) (b) (h)	 0,37 kw 220 V



EFE 04
PRATİKO OTO. KAPAKLI
PRATICO AUTO. BY COVER

 KG 167 kg	 250
 a b h 680x790x1315 (a) (b) (h)	 0,37 kw 220 V



EFE 04-1
PRATİKO OTO. SENSÖRLÜ
PRATICO AUTO. BY SENSOR

 KG 166 kg	 350
 a b h 680x790x1200 (a) (b) (h)	 0,37 kw 220 V



EFE 05
SELF SERVİS
SELF SERVICE

 KG 181 kg	 250
 a b h 680x793x1369 (a) (b) (h)	 0,37 kw 220 V



EFE 06
ECO MANUEL
ECO MANUAL

 KG 125 kg	 500
 a b h 720x750x1145 (a) (b) (h)	 0,37 kw 220 V



EFE 06-1
SLİM ECO MANUEL
SLİM ECO MANUAL

 KG 105 kg	 400
 a b h 580x750x1145 (a) (b) (h)	 0,37 kw 220 V



EFE 06-2
SLİM ECO SENSÖRLÜ
SLİM ECO BY SENSOR

 KG 100 kg	 250
 a b h 480x750x1145 (a) (b) (h)	 0,37 kw 220 V



EFE 07
TRABZON MANUEL
TRABZON MANUAL

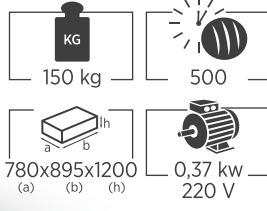

ÖZEL İMALAT/TASARIM MAKİNE
SPECIAL MANUFACTURING SLICER MACHINE



EKMEK DİLİMLEME GRUBU
BREAD SLICER GROUP



EFE 08
YATAY BIÇAKLI MANUEL
HORIZONTAL MANUAL

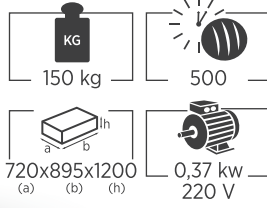

PKM 01
PNOMATİK KLİPS MAKİNESİ
PNEUMATIC CLIPS MACHINE

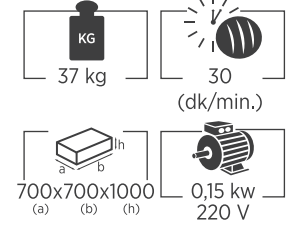

EFE 08-1
YATAY BIÇAKLI OTO. SENSÖRLÜ
HORIZONTAL AUTO. BY SENSOR

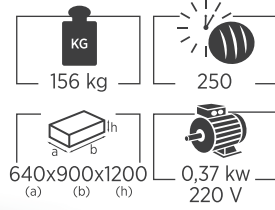

FK 02
FESTİNA KLİPS MAKİNESİ
FESTINA CLIPS MACHINE

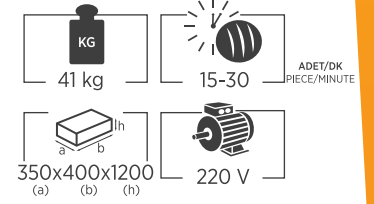

EFE 09
HERCULES

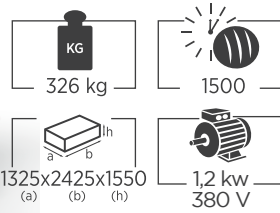

PS 01
POŞE TLEME SEHPASI
PACKING TABLE

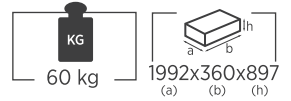

EFE 10
STİLL DAİRESEL
STILL CYCLE

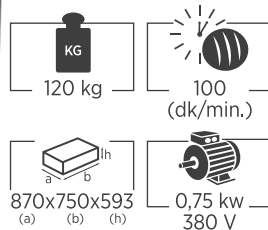

PDT 01
POŞETLENMİŞ EKMEK TABLOSU
PACKED BREAD TROLLEY

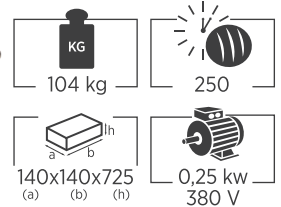



**SPIRAL MIKSER GRUBU
SPIRAL MIXER GROUP**



**SM 10
MINI CHEF**

 6	 10	 11
 35	 230 V 0,37 kW	 310 (a) x510 (b) x430 (h)



**SM 10-1
MINI CHEF PRO**

 6	 10	 12
 35	 230 V 0,37 kW	 300 (a) x532 (b) x539 (h)



SM 20

 12	 20	 30
 120	 380 V 1-1,6 kW	 430 (a) x881 (b) x945 (h)



SM 40

 25	 40	 55
 233	 380 V 1,5-2,5 kW	 530 (a) x1033 (b) x1078 (h)

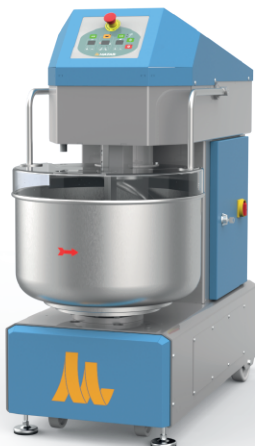

SM 60

 35	 60	 95
 510	 380 V 2,2-3,4 kW	 630 (a) x1273 (b) x1376 (h)

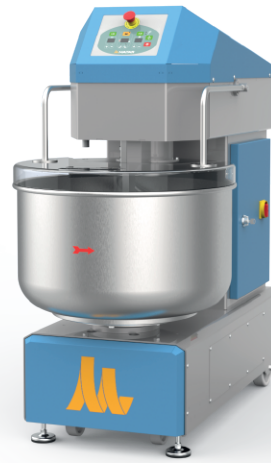

SM 100

 62,5	 100	 145
 540	 380 V 3,5-5,5 kW	 736 (a) x1354 (b) x1429 (h)



SM 130

 80	 130	 200
 688	 380 V 4-6,5 kW	 850 (a) x1548 (b) x1505 (h)

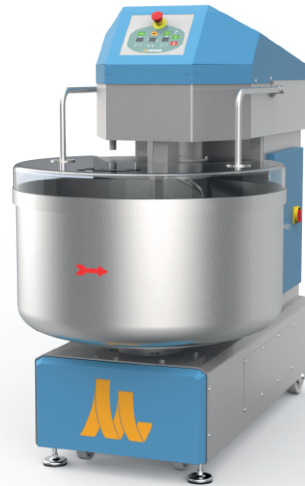

SM 200

 125	 200	 290
 726	 380 V 5-8 kW	 926 (a) x1591 (b) x1541 (h)

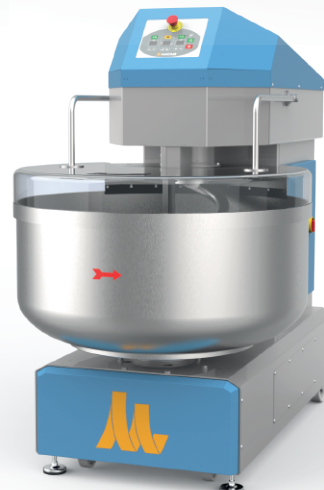







SM 250

 150	 250	 350
 900	 380 V 6-10 kW	 1026 (a) x1745 (b) x1605 (h)

MSM 250
MOBİL SİRAL MİKSER
MOBILE SPIRAL MIXER



 FLOUR (kg) 150	 DOUGH (kg) 250	 LT. 420
 KG 1610	 380 V 11-15 kW	 1250 (a) x2300 (b) x2050 (h)



SİRAL MİKSER GRUBU
SİRAL MIXER GROUP

HKD01
HİDROLİK KALDIR DEVİR MAKİNESİ
HDRAULIC BOWL TILTING MACHINE

Mataş Mobil Spiral Mikser (MSM 250) ve Mobil Promix (PSM 240-1) modelleri ile uyumlu çalışmaktadır.

It is compatible with Mataş Mobile Spiral Mixer (MSM 250) and Mobil Promix (PSM 240-1) models.



 1178 (a) x1664 (b) x3079 (h)

 KG 575
--

 380 V 5-8 kW
--

SKKD
SABİT KAZANLI KALDIR-DEVİR
TILT OVER SPIRAL MIXER

Promix ve bıçaklı spiral mikserlerimize uyumlu çalışır. Hidrolik sistemli, mikser kaldır-devir makinesidir. Güçlü, titreşimsiz ve sessiz çalışır. İşletmenin konumuna göre üretilir. CE ve kaliteli elektrik malzemelerinden imal edilmiştir.

Tilt over spiral mixer works in coordination with Promix and Spiral Mixers. Tilt over spiral mixer has hydraulic system. The machine works strong, vibration free and silent. CE certificated and made of high quality electrical materials.

 KG 1700

 380 V 11-15 kW
--

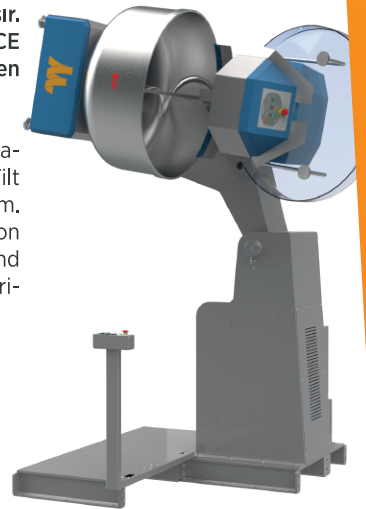



PMX 01
10 LT.

FLOUR (kg)	DOUGH (kg)	EGG
3	4,5	30
KG		
49	230 V 0,37 kW	421 (a) x610 (b) x637 (h)



PMX 02
20 LT.

FLOUR (kg)	DOUGH (kg)	EGG
4	5,5-6	40
KG		
75	230 V 0,55 kW	650 (a) x730 (b) x730 (h)



PMX 03
30 LT.

FLOUR (kg)	DOUGH (kg)	EGG
5	7,5	50
KG		
245	380 V 1,5 kW	820 (a) x930 (b) x1500 (h)



PMX 04
40 LT.

FLOUR (kg)	DOUGH (kg)	EGG
7	10,5	60
KG		
247	380 V 1,5 kW	850 (a) x930 (b) x1500 (h)



PMX 05-1
60 LT. ECO

FLOUR (kg)	DOUGH (kg)	EGG
10	15	120
KG		
285	380 V 1-1,5-1,85 kW	950 (a) x990 (b) x1470 (h)



PMX 05
60 LT.

FLOUR (kg)	DOUGH (kg)	EGG
10	15	120
KG		
362	380 V 2 kW	920 (a) x1150 (b) x1550 (h)



PMX 06
80 LT.

FLOUR (kg)	DOUGH (kg)	EGG
16	24	150
KG		
375	380 V 3 kW	1080 (a) x1160 (b) x1630 (h)



PMX 07
80 LT. AUTO.

FLOUR (kg)	DOUGH (kg)	EGG
16	24	150
KG		
443	380 V 3 kW	1070 (a) x1160 (b) x1900 (h)



PLANET MIKSER KAZANI KALDIR-DEVİR
AUTO. BOWL TILTING MACHINE

KG		
362	380 V 1,5 kW	1250 (a) x1470 (b) x2485 (h)



PSM 40

FLOUR (kg)	DOUGH (kg)	LT.
25	40	55
KG	380 V 1,5-3 kW	559 (a) x1168 (b) x1121 (h)
240		



PSM 80

FLOUR (kg)	DOUGH (kg)	LT.
50	85	120
KG	380 V 3,5-5,5 kW	676 (a) x1377 (b) x1411 (h)
620		

BIÇAKSIZ KAZAN !



WITHOUT BREAKER BAR !



PSM 160

FLOUR (kg)	DOUGH (kg)	LT.
100	170	250
KG	380 V 5-8 kW	880 (a) x1647 (b) x1539 (h)
790		



PSM 240

FLOUR (kg)	DOUGH (kg)	LT.
150	255	350
KG	380 V 6-10 kW	1002 (a) x1733 (b) x1579 (h)
835		



PSM 240-1
MOBİL PROMIX SİRİRAL MİKSER
MOBILE PROMIX SİRİRAL MIXER

FLOUR (kg)	DOUGH (kg)	LT.
150	255	425
KG	380 V 6-10 kW	1295 (a) x2112 (b) x1708 (h)
2200		

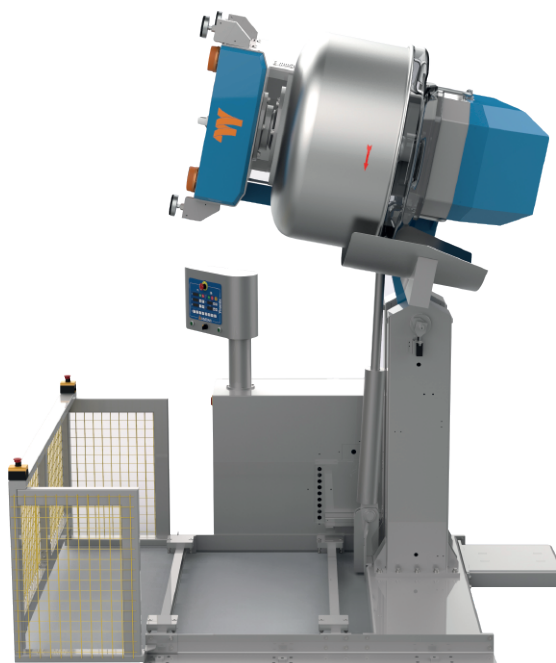

SKKD
SABİT KAZANLI KALDIR-DEVİR
TILT OVER SİRİRAL MIXER

KG	380 V
1700	
PSM 80 : 7,5-9,5 kw PSM 160 : 9-12 kw PSM 240 : 10-14 kw	



HKT 01
HAMUR KESME TARTMA MAKİNESİ
VOLUMETRIC DOUGH DIVIDER MACHINE

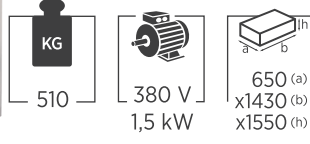

GRAMAJ WEIGHT	KAPASİTE(saat) CAPACITY (hour)
Q60 : 50-150 gr.	1000-2000
Q80 : 70-350 gr.	1000-2000
Q90 : 90-420 gr.	1000-2000
Q100 : 90-600 gr.	1000-2000
Q110 : 120-600 gr.	1000-2000
Q130 : 200-900 gr.	1000-2500



HKT 02
MİNİ HAMUR KESME TARTMA MAKİNESİ
MINI VOLUMETRIC DOUGH DIVIDER MACHINE

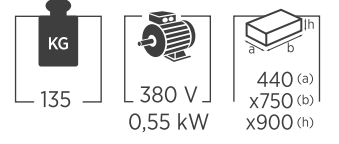

GRAMAJ WEIGHT	KAPASİTE(saat) CAPACITY (hour)
30-170 gr.	2700



HKC 01
HAMUR KONİK ÇEVİRME MAKİNESİ
CONICAL ROUNDING MACHINE

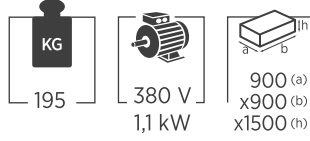

OPSİYONEL | OPTIONAL

50-150 gr.
100-600 gr.
100-600 gr.



IUN 01
İPEK UN ELEME MAKİNESİ
SIFT FLOUR MACHINE

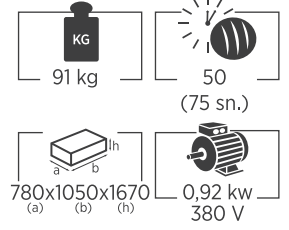

GLT 01
BAYAT EKMEK ÖĞÜTME MAKİNESİ
BREAD CRUMBS MACHINE

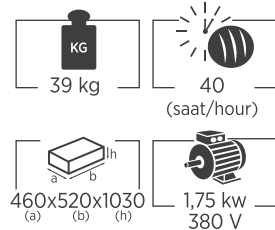

PM 01
PUDRA ŞEKERİ MAKİNESİ
POWDERED SUGAR MACHINE

